

Features

- 1-port Resonator
- Provides reliable, fundamental mode, quartz frequency stabilization i.e. in transmitters or local oscillators
- Package size 1.8*1.4
- Lead-free production and RoHS compliance

Package Dimensions

Ceramic Package(Unit: mm):

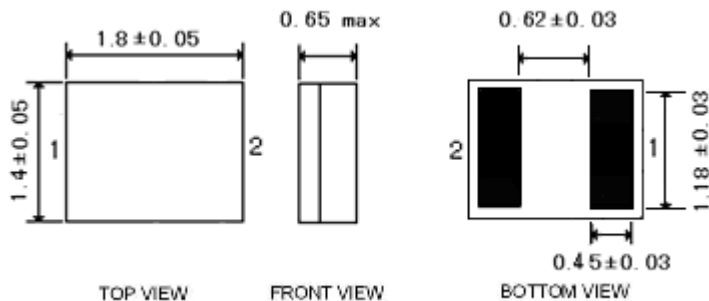

Pin Configuration

1	Input
2	Output

Marking

Top View, Laser Marking

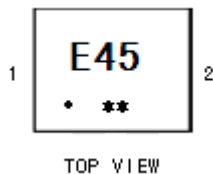

"E45" Part number

“.” Dot marking, indicates input 1

1,2 Terminal1, Terminal2

TOP VIEW

The first “*”: Month Code (The code shown below varies in a 4-year cycle)

Month	1	2	3	4	5	6	7	8	9	10	11	12
2016/2020	n	p	q	r	s	t	u	v	w	x	y	z
2017/2021	A	B	C	D	E	F	G	H	J	K	L	M
2018/2022	N	P	Q	R	S	T	U	V	W	X	Y	Z
2019/2023	a	b	c	d	e	f	g	h	i	j	k	m

The second “*”: Date Code

data	1st	2nd	3rd	4th	5th	6th	7th	8th	9th	10th	
code	A	B	C	D	E	F	G	H	J	K	
data	11th	12th	13th	14th	15th	16th	17th	18th	19th	20th	
code	L	M	N	P	Q	R	S	T	U	V	
data	21st	22nd	23rd	24th	25th	26th	27th	28th	29th	30th	31st
code	W	X	Y	Z	a	b	d	e	f	g	h

Maximum Ratings

Rating		Value	Unit
CW RF power dissipation	P	10	dBm
DC voltage between any terminals	V_{DC}	± 30	V
Operating temperature range	T_A	-40 ~ +85	$^{\circ}\text{C}$
Storage temperature range	T_{stg}	-40 ~ +85	$^{\circ}\text{C}$

Electrical Characteristics

Characteristic		Sym	Minimum	Typical	Maximum	Unit
Center Frequency (+25 $^{\circ}\text{C}$)	Absolute Frequency	f_c	433.82		434.02	MHz
	Tolerance from 433.920 MHz	Δf_c			± 100	kHz
Insertion Loss		IL		1.6	2	dB
Quality Factor	Unloaded Q	Q_U		9510		
	50 Ω Loaded Q	Q_L		1600		
Temperature Stability	Turnover Temperature	T_0	5	20	35	$^{\circ}\text{C}$
	Turnover Frequency	f_0		f_c		kHz
	Frequency Temperature Coefficient	FTC		-0.016		ppm/ $^{\circ}\text{C}^2$
Frequency Aging	Absolute Value during the First Year	$ f_A $		≤ 10		ppm/yr
DC Insulation Resistance Between Any Two Terminals			1.0			M Ω
RF Equivalent RLC Model	Motional Resistance	R_M		20.23	25	Ω
	Motional Inductance	L_M		70.591		μH
	Motional Capacitance	C_M		1.908		fF
	Shunt Static Capacitance	C_0	1.8	2	2.2	pF

 RoHS Compliant

 Electrostatic Sensitive Device

NOTE:

1. Unless noted otherwise, case temperature $T_C = +25^{\circ}\text{C} \pm 2^{\circ}\text{C}$.
2. The center frequency, f_c , is measured at the minimum insertion loss point with the resonator in the 50 Ω test system.
3. Frequency aging is the change in f_c with time and is specified at +65 $^{\circ}\text{C}$ or less. Aging may exceed the specification for prolonged temperatures above +65 $^{\circ}\text{C}$. Typically, aging is greatest the first year after manufacture, decreasing in subsequent years.
4. Turnover temperature, T_0 , is the temperature of maximum (or turnover) frequency, f_0 . The nominal frequency at any case temperature, T_C , may be calculated from: $f = f_0 [1 - \text{FTC} (T_0 - T_C)^2]$.
5. This equivalent RLC model approximates resonator performance near the resonant frequency and is provided for reference only. The capacitance C_0 is the static capacitance between the two terminals measured at low frequency (10MHz) with a capacitance meter. The measurement includes case parasitic capacitance.

Typical Frequency Response
S21

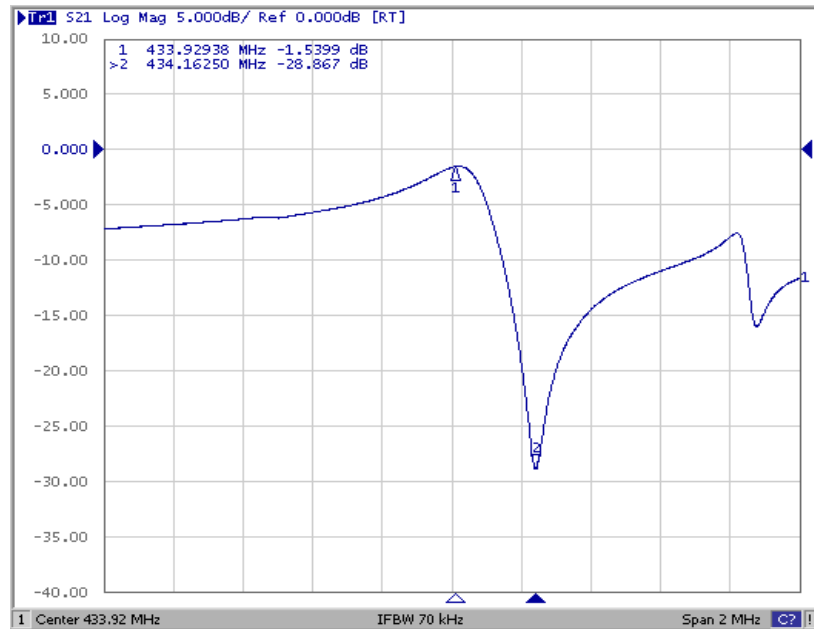

Test Circuit

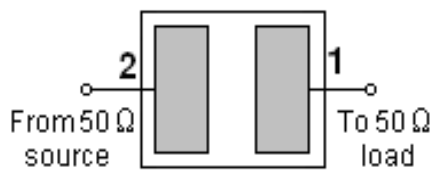

Temperature Characteristics

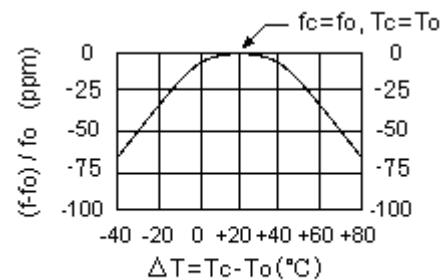

The curve shown above accounts for resonator contribution only.

Typical Application Circuits

1) Low-Power Transmitter Application

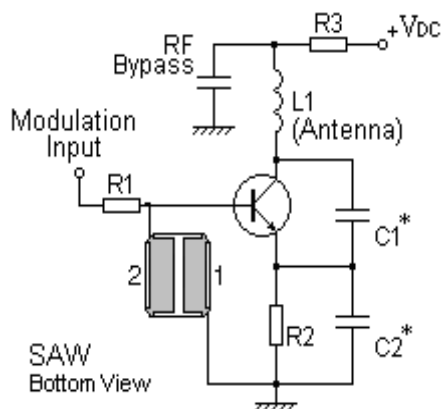

2) Local Oscillator Application

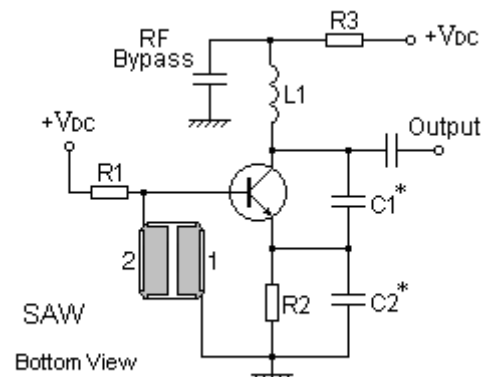

Stability Characteristics

Item No.	Test Item	STD Reference	Test Conditions	per lot
Preconditioning		JESD22-A113	1) Temperature Cycling, 5 cycles -40°C to 85°C 2) Bake, 24 hrs @125±5°C; 3) Reflow, 3 reflow cycles using profiles per IPC/JEDEC J-STD-020, SnPb or Pb-free profile based on device end use process 4) Drying, Room ambient temperature	177
1	Temperature Cycling	JESD22-A104	-40°C / +85°C, 40min dwell, <1 min transfer time, 500cycles	23
2	High Temperature Storage	JESD22-A103	85°C, 240hr	23
3	Low Temperature Storage	JESD22-A119	-40°C, 240hr	23
4	High Temp. High Humidity Storage	JESD22-A106B	85°C, 85%RH, 240hr	23
5	High Temperature Operating	JESD22-A102C	+121°C 100%RH 96hr	23
6	Human Body Mode ESD	JESD22-A114	Measure to get the ESD limits level or margin beyond specification	5
7	Drop Test	IEC 68-2-32	100 cm 3times Steel floor JIG(110g~150g)	6
8	Solder ability	JESD22-B102	Characterization per JESD22-B102	5
9	Vibration, Variable Frequency	JESD22-B103	20 Hz to 2 kHz (log variation) in > 4 minutes, 4X in each orientation, 50g peak acceleration	23
10	Mechanical Shock	JESD22-B104	Y1 plane only, 5 pulses, 0.5 ms duration, 1500 g peak acceleration	23

Requirements: The SAW filter shall remain within the electrical specifications after tests.

Remarks

- SAW devices should not be used in any type of fluid such as water, oil, organic solvent, etc.
- Be certain not to apply voltage exceeding the rated voltage of components.
- Do not operate outside the recommended operating temperature range of components.
- Sudden change of temperature shall be avoided, deterioration of the characteristics can occur.
- Be careful of soldering temperature and duration of components when soldering.
- Do not place soldering iron on the body of components.
- Be careful not to subject the terminals or leads of components to excessive force.
- SAW devices are electrostatic sensitive. Please avoid static voltage during operation and storage.
- Ultrasonic cleaning shall be avoided. Ultrasonic vibration may cause destruction of components.

Packing Information

Carrier Tape

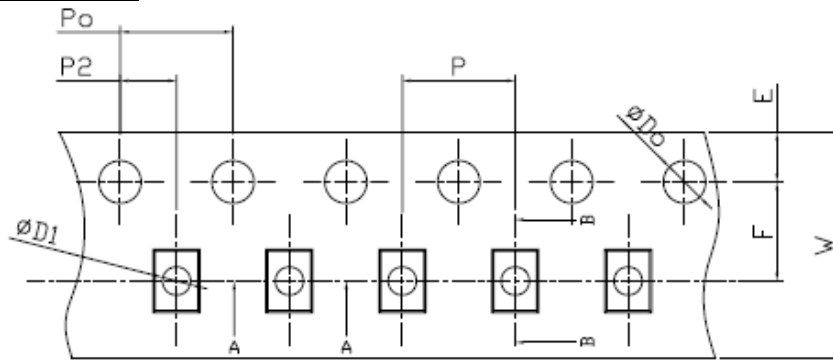

SYMBOL	E	F	P2	D0	D1	P0
SPEC	1.75±0.10	3.50±0.05	2.00±0.05	1.55±0.05	0.60±0.05	4.00±0.10
SYMBOL	W	P	A0	B0	K0	t
SPEC	8.00±0.10	4.00±0.10	1.60±0.05	2.10±0.10	0.80±0.05	0.30±0.10

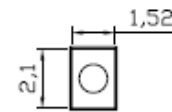

Reel Dimensions

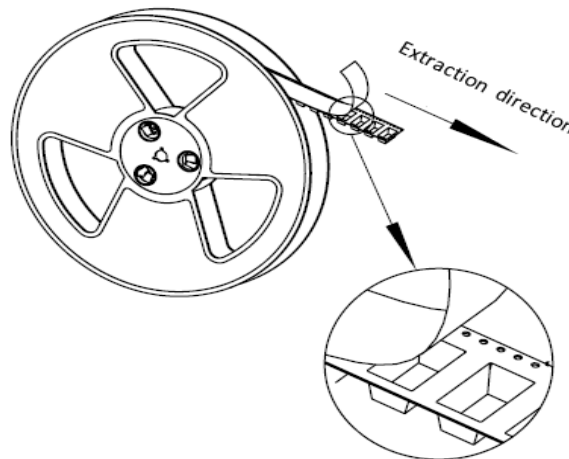

Material	PS
Unit	mm
Tolerance	±0.20 mm
Quantity	3000/reel

Outer Packing

Type	Quantity	Dimension	Description	Weight
Carton Box I	15000	190x190x95	anti-static plastic bag & carton box 1 reel / bag	0.85
Carton Box II	30000	190x190x190	5 bags / box (15000 pcs) 10 bags / box (30000 pcs)	1.80

Unit: mm

Unit: kg

Recommended Soldering Profile

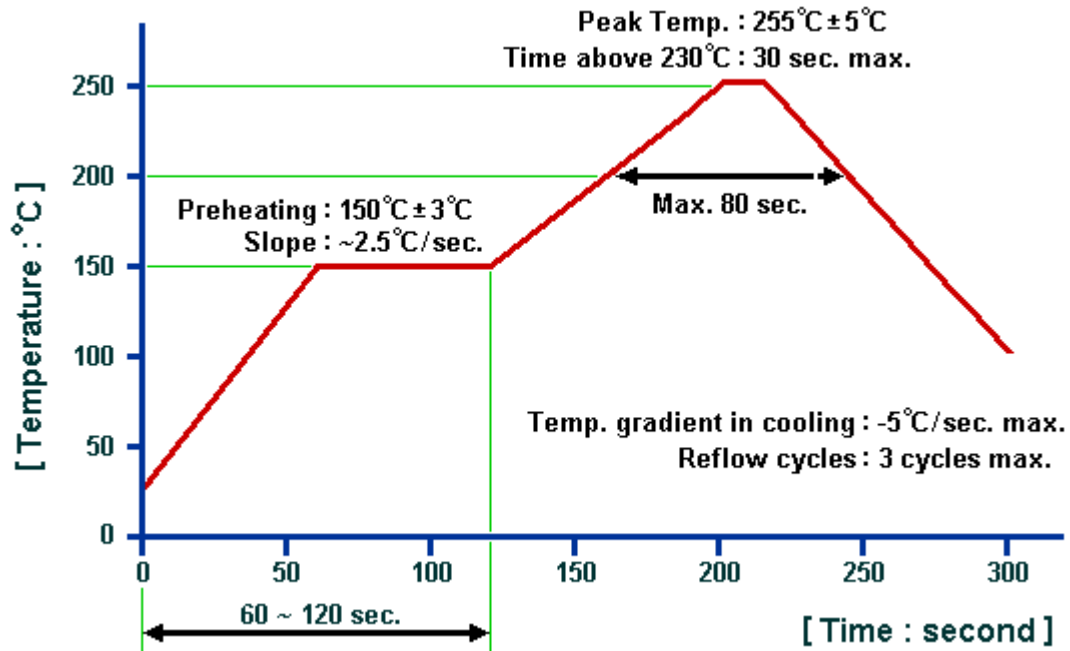

© NEDI 2018. All Rights Reserved.

1. The specifications of this device are subject to change or obsolescence without notice.
2. Typically, equipment utilizing this device requires emissions testing and government approval, which is the responsibility of the equipment manufacturer.
3. Our liability is only assumed for the Surface Acoustic Wave (SAW) component(s) per se, not for applications, processes and circuits implemented within components or assemblies.
4. For questions on technology, prices and delivery, please contact our sales offices or e-mail _____.